



MH 275 Specifications

Low Sensitivity Omni-polar Hall Switch

MH275 Hall effect switch is a temperature stable, Superior high-temperature performance is made possible through a dynamic offset cancellation that utilizes chopper-stabilization.

MH275 includes the following on a single silicon chip: voltage regulator, Hall voltage generator, small-signal amplifier, chopper stabilization, Schmitt trigger, and open drain output. Advanced DMOS wafer fabrication processing is used to take advantage of low-voltage requirements, component matching, very low input-offset errors, and small component geometries.

This device requires the presence of omni-polar magnetic fields for operation.

MH275 is rated for operation between the ambient temperatures -40°C and $+85^{\circ}\text{C}$ for the E temperature range. and -40°C to 125°C for the K temperature range. The two package styles available provide magnetically optimized solutions for most applications. Package types SO is an SOT-23, a miniature low-profile surface-mount package, while package UA is a three-lead ultra-mini SIP for through-hole mounting.

The package type is in a Halogen Free version was verified by third party Lab.

Features and Benefits

- DMOS Hall IC Technology.
- Operation range from 2.5V to 26V .
- Omni polar, output switches with absolute value of North or South pole from magnet.
- Reverse bias protection on power supply pin.
- High Sensitivity for reed switch replacement applications.
- Low sensitivity drift in crossing of Temp range.
- High ESD Protection, HBM $>\pm 4\text{KV}(\text{min})$
- Output Current limit in 100mA.
- RoHS compliant 2011/65/EU and Halogen Free

Applications

- Solid state switch.
- Limit switch.
- Current limit.
- Interrupter.
- Magnet proximity sensor for reed switch replacement.

Ordering Information

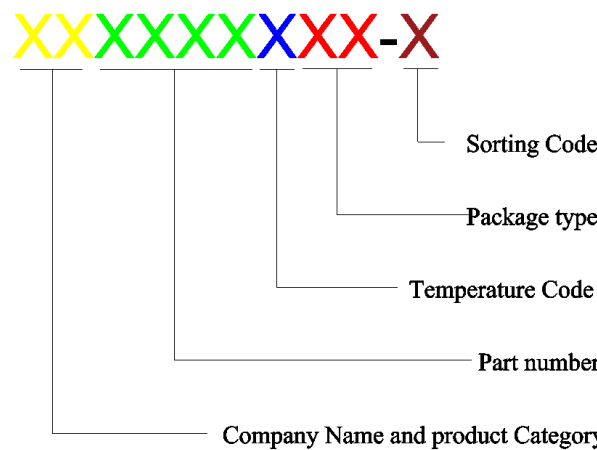
	<p>Company Name and Product Category</p> <p>MH:MST Hall Effect/MP:MST Power MOSFET</p> <p>Part number</p> <p>181,182,183,184,185,248,249,276,477,381,381F,381R,382.....</p> <p>If part # is just 3 digits, the forth digit will be omitted.</p> <p>Temperature range</p> <p>E: 85 °C, I: 105 °C, K: 125 °C, L: 150 °C</p> <p>Package type</p> <p>UA:TO-92S,VK:TO-92S(4pin),VF:TO-92S(5pin),SO:SOT-23, SQ:QFN-3,ST:TSOT-23,SN:SOT-553,SF:SOT-89(5pin)</p> <p>Sorting</p> <p>α,β,Blank.....</p>
---	---

Part No.	Temperature Suffix	Package Type
MH275KUA	K (-40°C to + 125°C)	UA (TO-92S)
MH275EUA	E (-40°C to + 85°C)	UA (TO-92S)
MH275KSO	K (-40°C to + 125°C)	SO (SOT-23)
MH275ESO	E (-40°C to + 85°C)	SO (SOT-23)

KUA spec is using in industrial and automotive application. Special Hot Testing is utilized.

Functional Diagram

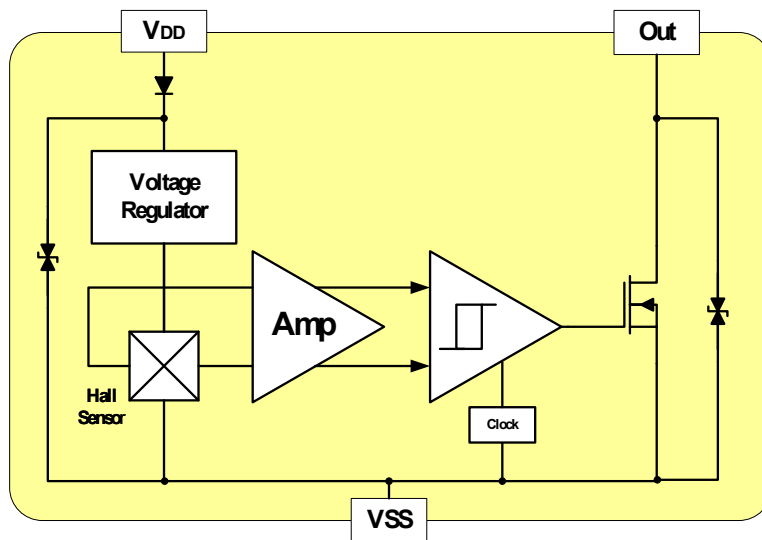

Absolute Maximum Ratings At ($T_a=25^\circ\text{C}$)

Characteristics		Values	Unit
Supply voltage, (V_{DD})		28	V
Output Voltage, (V_{OUT})		28	V
Reverse Voltage, (V_{DD} / V_{OUT})		-28/-0.3	V
Output current, (I_{SINK})		25	mA
Operating Temperature Range, (T_A)	“E” Class	-40 ~ +85	$^\circ\text{C}$
	“K” Class	-40 ~ +125	$^\circ\text{C}$
Storage temperature Range, (T_S)		-55 ~ +150	$^\circ\text{C}$
Maximum Junction Temp, (T_J)		150	$^\circ\text{C}$
Thermal Resistance	(θ_{JA}) UA/ SO	206 / 543	$^\circ\text{C}/\text{w}$
	(θ_{JC}) UA/ SO	148 / 410	$^\circ\text{C}/\text{w}$
Package Power Dissipation, (P_D)		606 / 230	mW

Note: Do not apply reverse voltage to V_{DD} and V_{OUT} Pin, It may be caused for Miss function or damaged device.

Electrical Specifications

DC Operating Parameters : $T_A=+25^\circ\text{C}$, $V_{DD}=12\text{V}$

Parameters	Test Conditions	Min	Typ	Max	Units
Supply Voltage, (V_{DD})	Operating	2.5		26.0	V
Supply Current, (I_{DD})	$B < B_{OP}$		2.5	5.0	mA
Output Saturation Voltage, ($V_{DS(ON)}$)	$I_{OUT}=20\text{mA}$, $B > B_{OP}$		300	500.0	mV
Output Leakage Current, (I_{OFF})	I_{OFF} $B < B_{RP}$, $V_{OUT} = 20\text{V}$			10.0	μA
Output Limited Current, (I_{CO})	$B > B_{OP}$		100		mA
Power-On Time, (T_{PO})	Power-On			100	μs
Output Switch Time, (T_{SW})	Operating			100	μs
Output Switch Frequency, (F_{SW})	Operating	5			kHz
Output Rise Time, (T_R)	$R_L=1\text{k}\Omega$, $C_L=20\text{pF}$		0.1	0.45	μs
Output Fall Time, (T_F)	$R_L=1\text{k}\Omega$; $C_L=20\text{pF}$		6.0	10	μs
Electro-Static Discharge	HBM	4			KV
Operate Point, $B_{OPS}(B_{OPN})$	$B > B_{OPS}(B < B_{OPN})$, V_{OUT} On	140(-250)		250(-140)	Gauss
Release Point, $B_{RPS}(B_{RPN})$	$B < B_{RPS}(B > B_{RPN})$, V_{OUT} Off	95(-205)		205(-95)	Gauss
Hysteresis, (B_{HYS})	$ B_{OPX} - B_{RPX} $		45		Gauss

Typical application circuit

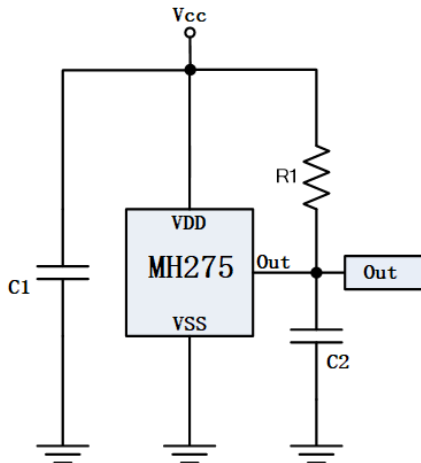

C1 : 10nF
C2 : 1nF
R1 : 1K Ω

Sensor Location, Package Dimension and Marking

UA Package

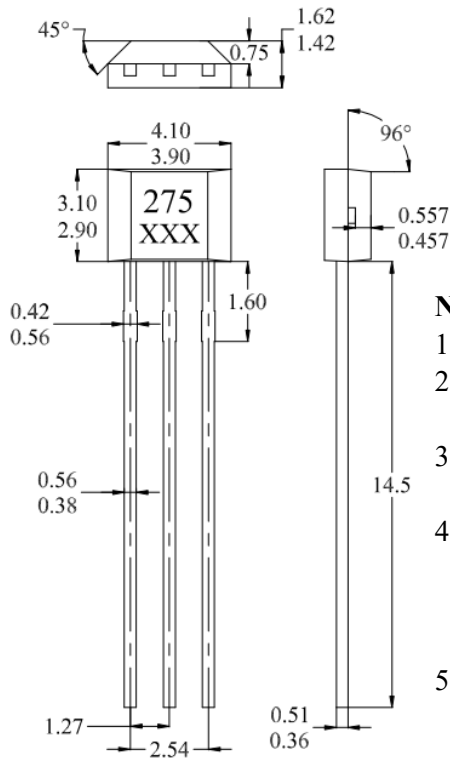

NOTES:

- Controlling dimension: mm
- Leads must be free of flash and plating voids
- Do not bend leads within 1 mm of lead to package interface.
- PINOUT:
Pin 1 VDD
Pin 2 GND
Pin 3 Output
- XXX; 1st X=Year;
2nd and 3rd XX=Week

Hall Chip location

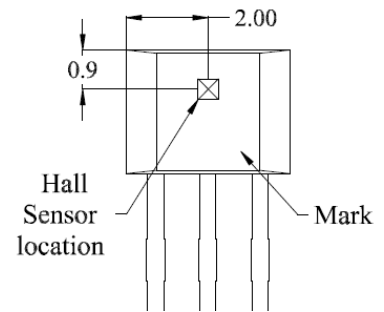

Output Pin Assignment

(Top view)

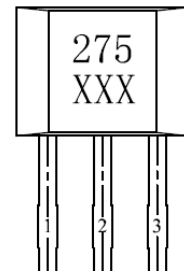

Package (SOT-23)

(Top View)

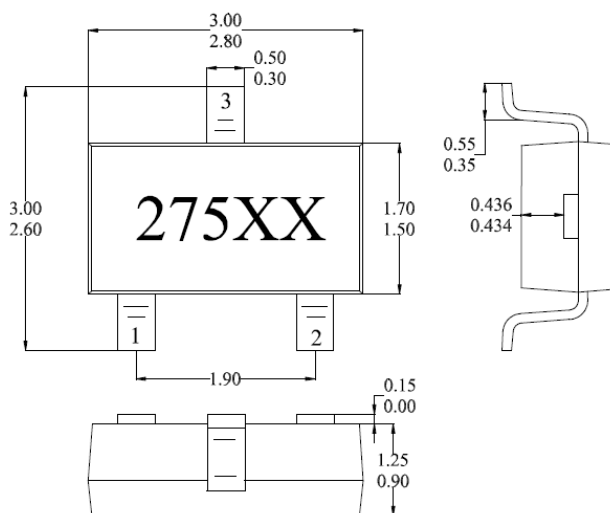

NOTES:

- PINOUT (See Top View at left :)
Pin 1 V_{DD}; Pin 2 Output; Pin 3 GND
- Controlling dimension: mm
- Lead thickness after solder plating will be 0.254mm maximum
- XX: Date Code, Refer to DC table

Hall Plate Chip Location

(Bottom view)

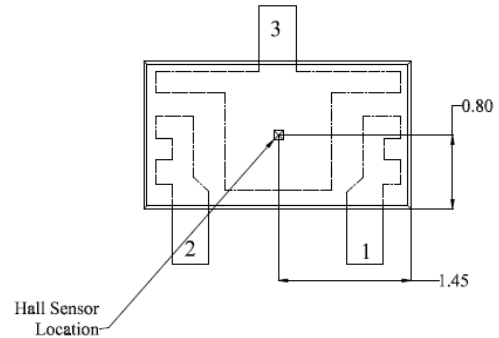

(For reference only) Land Pattern

