

MH182 Hall-Effect sensor is a temperature stable, stress-resistant latch. Superior high-temperature performance is made possible through a dynamic offset cancellation that utilizes chopper-stabilization. This method reduces the offset voltage normally caused by device over molding, temperature dependencies, and thermal stress.

MH182 includes the following on a single silicon chip: voltage regulator, Hall voltage generator, small-signal amplifier, chopper stabilization, Schmitt trigger, open-drain output. Advanced CMOS wafer fabrication processing is used to take advantage of low-voltage requirements, component matching, very low input-offset errors, and small component geometries.

This device requires the presence of both south and north polarity magnetic fields for operation. In the presence of a south polarity field of sufficient strength, the device output latches on, and only switches off when a north polarity field of sufficient strength is present.

MH182 is rated for operation between the ambient temperatures -40°C and 85°C for the E temperature range, and -40°C to 125°C for the K temperature range. The two package styles available provide magnetically optimized solutions for most applications. Package SO is an SOT-23, a miniature low-profile surface-mount package, while package UA is a three-lead ultra mini SIP for through-hole mounting.

The package type is in a Halogen Free version was verified by third party Lab.

Features and Benefits

- Chopper stabilized amplifier stage
- Optimized for BLDC motor applications
- New miniature package / thin, high reliability package
- Operation down to 3.0V
- 100% tested at 125°C for K.
- Custom sensitivity / Temperature selection are available.
- RoHS compliant 2011/65/EU and Halogen Free

Applications

- High temperature Fan motor
- 3 phase BLDC motor application
- Speed sensing
- Position sensing
- Current sensing
- Revolution counting
- Solid-State Switch
- Linear Position Detection
- Angular Position Detection
- Proximity Detection

Ordering Information

| | |
|---|--|
|  | <p>Company Name and Product Category</p> <p>MH:MST Hall Effect/MP:MST Power IC</p> <p>Part number</p> <p>181,182,183,184,185,248,249,276,477,381,381F,381R,382.....</p> <p>If part # is just 3 digits, the fourth digit will be omitted.</p> <p>Temperature range</p> <p>E: 85 °C, I: 105 °C, K: 125 °C, L: 150 °C</p> <p>Package type</p> <p>UA:TO-92S,VK:TO-92S(4pin),VF:TO-92S(5pin),SO:SOT-23, SQ:QFN-3,ST:TSOT-23,SN:SOT-553,SF:SOT-89(5pin), SS:TSOT-26,SD:DFN-6</p> <p>Sorting</p> <p>α,β,Blank.....</p> |
| <p>Sorting Code</p> <p>Package type</p> <p>Temperature Code</p> <p>Part number</p> <p>Company Name and product Category</p> | |

| Part No. | Temperature Suffix | Package Type |
|----------|----------------------|--------------|
| MH182KUA | K (-40°C to + 125°C) | UA (TO-92S) |
| MH182KSO | K (-40°C to + 125°C) | SO (SOT-23) |
| MH182EUA | E (-40°C to + 85°C) | UA (TO-92S) |
| MH182ESO | E (-40°C to + 85°C) | SO (SOT-23) |

KUA spec is using in industrial and automotive application. Special Hot Testing is utilized.

Functional Diagram

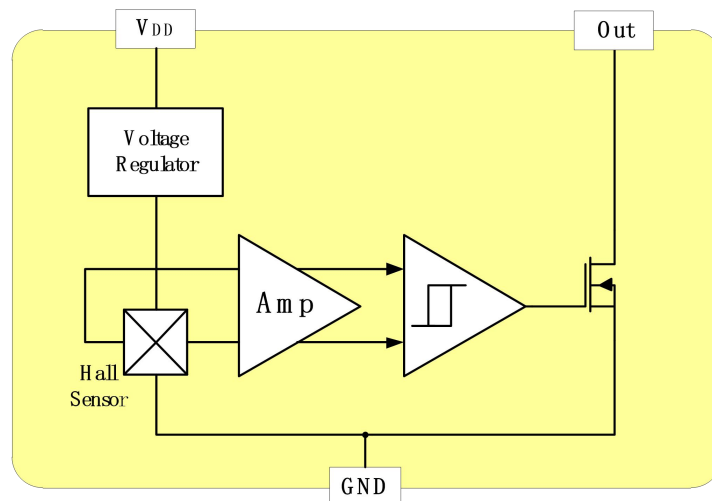

Absolute Maximum Ratings At ($T_A=25\text{ }^\circ\text{C}$)

| Characteristics | | Values | Unit |
|--|---------------------------|-------------|---------------------------|
| Supply voltage, (V_{DD}) | | 26 | V |
| Output Voltage, (V_{out}) | | 26 | V |
| Reverse voltage , (V_{DD}) (V_{our}) | | -0.3 | V |
| Output current , (I_{out}) | | 50 | mA |
| Operating Temperature Range, (T_A) | “E” version | -40 to +85 | $^\circ\text{C}$ |
| | “K” version | -40 to +125 | $^\circ\text{C}$ |
| Storage temperature range, (T_s) | | -65 to +150 | $^\circ\text{C}$ |
| Maximum Junction Temp, (T_j) | | 150 | $^\circ\text{C}$ |
| Thermal Resistance | (θ_{ja}) UA / SO | 206 / 543 | $^\circ\text{C}/\text{W}$ |
| | (θ_{jc}) UA / SO | 148 / 410 | $^\circ\text{C}/\text{W}$ |
| Package Power Dissipation, (P_D) UA / SO | | 606 / 230 | mW |

Note: Do not apply reverse voltage to V_{DD} and V_{OUT} Pin, It may be caused for Miss function or damaged device.

Electrical Specifications

DC Operating Parameters: $T_A=+25\text{ }^\circ\text{C}$, $V_{DD}=12\text{V}$

| Parameters | Test Conditions | Min | Typ | Max | Units |
|--|---|-----|-----|-------|---------------|
| Supply Voltage, (V_{DD}) | Operating | 3.0 | | 24.0 | V |
| Supply Current, (I_{DD}) | B<BOP | | | 5.0 | mA |
| Output Saturation Voltage, (V_{sat}) | $I_{out} = 20\text{ mA}$, B>BOP | | | 400.0 | mV |
| Output Leakage Current, (I_{off}) | I_{OFF} B<BRP, $V_{OUT} = 12\text{V}$ | | | 15.0 | μA |
| Output Rise Time, (T_R) | $R_L=1.1\text{ k}\Omega$, $C_L=20\text{ pF}$ | | | 0.45 | μs |
| Output Fall Time, (T_F) | $R_L=820\Omega$; $C_L=20\text{ pF}$ | | | 0.45 | μs |
| Switching Frequency, (F_{SW}) | | | 10 | | kHz |

Typical Application Circuit

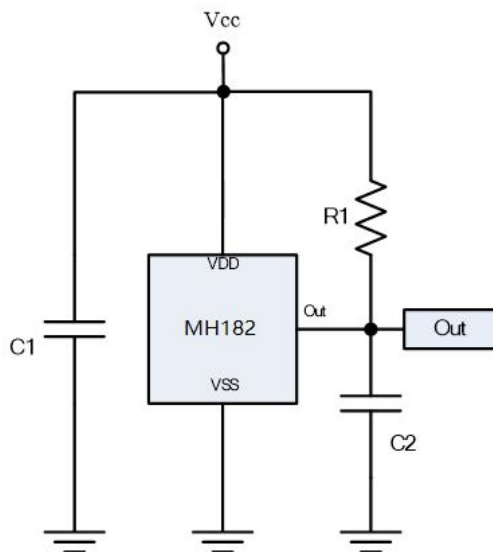

C1 : 10nF
 C2 : 1nF
 R1 : 1K Ω

MH182 Magnetic Specifications

DC Operating Parameters: $T_A=25\text{ }^\circ\text{C}$, $V_{DD}=12\text{V}$

| Parameter | Symbol | Test condition | Min | Typ | Max | Unit |
|---------------|--------|----------------|---------|-----|---------|-------|
| Operate Point | BOP | UA(SO) | 10(-60) | | 60(-10) | Gauss |
| Release Point | BRP | UA(SO) | -60(10) | | -10(60) | Gauss |
| Hysteresis | BHYS | | | 80 | | Gauss |

Sensor Location, Package Dimension and Marking

UA Package

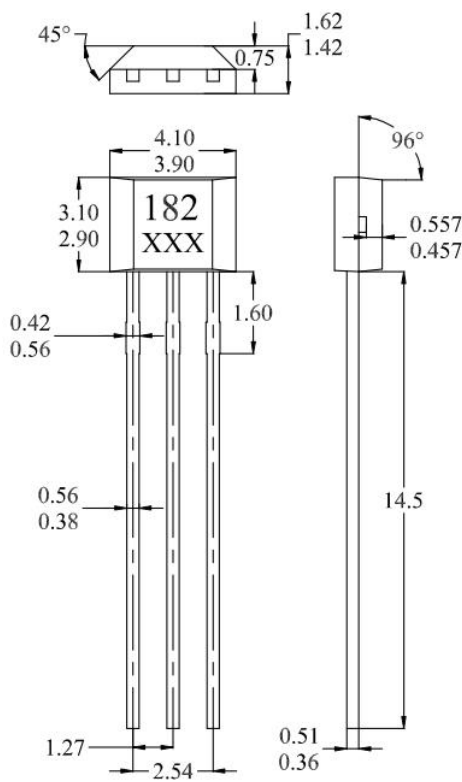

Hall Chip Location

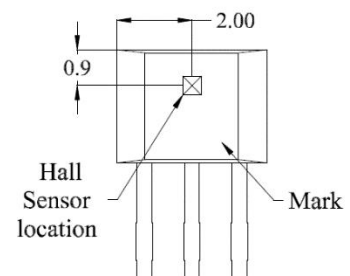

NOTES:

- Controlling dimension: mm
- Leads must be free of flash and plating voids
- Do not bend leads within 1 mm of lead to package interface.
- PINOUT:

| | |
|-------|--------|
| Pin 1 | VCC |
| Pin 2 | GND |
| Pin 3 | Output |
- XXX; 1st X=Year; 2nd and 3rd XX=Week

Output Pin Assignment

(Top view)

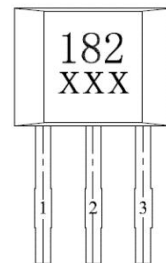

**SO Package
(Top View)**

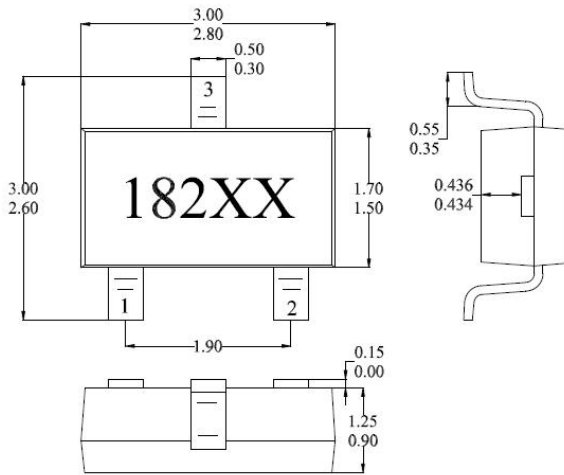

**Hall Plate Chip Location
(Bottom view)**

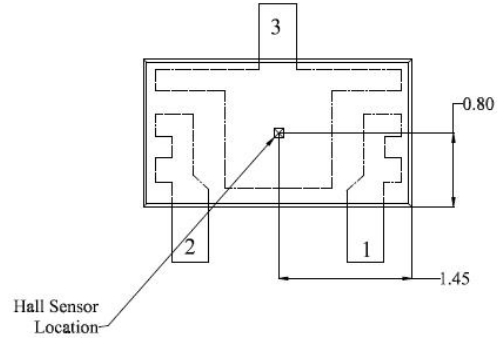

(For reference only) Land Pattern

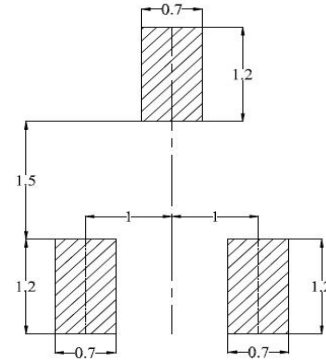

NOTES:

1. PINOUT (See Top View at left :)
Pin 1 :V_{DD}; Pin 2: Output ; Pin 3 GND
2. Controlling dimension: mm
3. Lead thickness after solder plating will be 0.254mm maximum
4. XX: Date Code, Refer to DC table