

MH251 Hall-effect sensor is a temperature stable, stress-resistant, Low Tolerance of Sensitivity micro-power switch. Superior high-temperature performance is made possible through a dynamic offset cancellation that utilizes chopper-stabilization. This method reduces the offset voltage normally caused by device over molding, temperature dependencies, and thermal stress.

MH251 is special made for low operation voltage, 1.65V, to active the chip which is includes the following on a single silicon chip: voltage regulator, Hall voltage generator, small-signal amplifier, chopper stabilization, Schmitt trigger, CMOS output driver. Advanced CMOS wafer fabrication processing is used to take advantage of low-voltage requirements, component matching, very low input-offset errors, and small component geometries. This device requires the presence of omni-polar magnetic fields for operation.

The package type is in a Halogen Free version has been verified by third party Lab.

### ***Features and Benefits***

- CMOS Hall IC Technology
- Strong RF noise protection
- 1.65 to 3.5V for battery-powered applications
- Omni polar, output switches with absolute value of North or South pole from magnet
- Operation down to 1.65V, Micro power consumption
- High Sensitivity for reed switch replacement applications
- Multi Small Size option
- Low sensitivity drift in crossing of Temp. range
- Ultra Low power consumption at 5uA (Avg)
- High ESD Protection, HBM >  $\pm 4$ KV( min )
- Totem-pole output
- RoHS compliant 2011/65/EU and Halogen Free.

### ***Applications***

- Solid state switch
- Handheld Wireless Handset Awake Switch ( Flip Cell/PHS Phone/Note Book/Flip Video Set)
- Lid close sensor for battery powered devices
- Magnet proximity sensor for reed switch replacement in low duty cycle applications
- Water Meter
- Floating Meter
- PDVD
- NB

### Ordering Information

	<p><b>Company Name and Product Category</b></p> <p>MH:MST Hall Effect/MP:MST Power IC</p> <p><b>Part number</b></p> <p>181,182,183,184,185,248,249,276,477,381,381F,381R,382.....</p> <p>If part # is just 3 digits, the fourth digit will be omitted.</p> <p><b>Temperature range</b></p> <p>E: 85 °C, I: 105 °C, K: 125 °C, L: 150 °C</p> <p><b>Package type</b></p> <p>UA:TO-92S,VK:TO-92S(4pin),VF:TO-92S(5pin),SO:SOT-23, SQ:QFN-3,ST:TSOT-23,SN:SOT-553,SF:SOT-89(5pin), SS:TSOT-26,SD:DFN-6</p> <p><b>Sorting</b></p> <p><math>\alpha</math>,<math>\beta</math>,Blank.....</p>
<p>Sorting Code</p> <p>Package type</p> <p>Temperature Code</p> <p>Part number</p> <p>Company Name and product Category</p>	

Part No.	Temperature Suffix	Package Type
MH251EST- $\beta$	E (-40°C to + 85°C)	ST (TSOT-23)
MH251ESQ- $\beta$	E (-40°C to + 85°C)	SQ (SQ2020-3)
MH251EUA- $\beta$	E (-40°C to + 85°C)	UA (TO-92S)

Custom sensitivity selection is available by MST sorting technology

### Functional Diagram

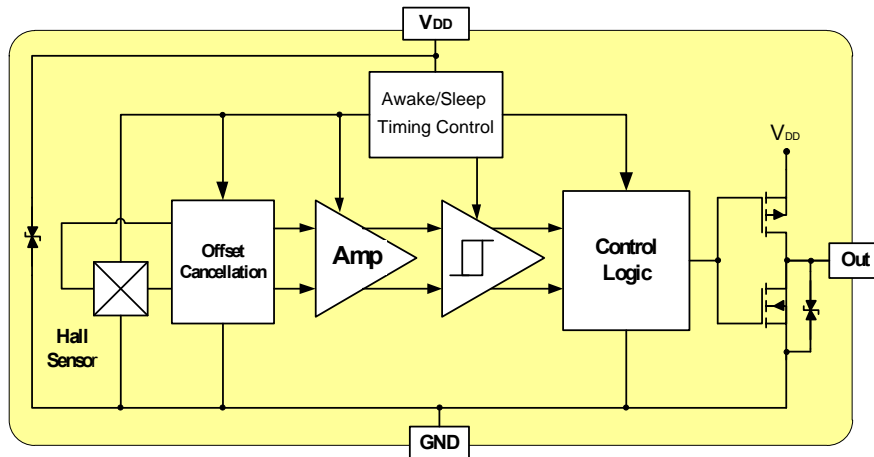

**Note:** Static sensitive device; please observe ESD precautions. Reverse  $V_{DD}$  protection is not included. For reverse voltage protection, a 100 $\Omega$  resistor in series with  $V_{DD}$  is recommended.

MH 251, HBM >  $\pm$ 4KV which is verified by third party lab.

#### Absolute Maximum Ratings At( $T_a=25^\circ\text{C}$ )

Characteristics	Values	Unit	
Supply voltage, ( $V_{DD}$ )	4.5	V	
Output Voltage, ( $V_{out}$ )	4.5	V	
Reverse Voltage, ( $V_{DD}$ ) ( $V_{out}$ )	-0.3	V	
Magnetic flux density	Unlimited	Gauss	
Output current, ( $I_{out}$ )	1	mA	
Operating temperature range, ( $T_a$ )	-40 to +85	$^\circ\text{C}$	
Storage temperature range, ( $T_s$ )	-65 to +150	$^\circ\text{C}$	
Maximum Junction Temp, ( $T_j$ )	150	$^\circ\text{C}$	
Thermal Resistance	$(\theta_{JA})$ ST / SQ/ UA	310 / 543/ 206	$^\circ\text{C}/\text{W}$
	$(\theta_{JC})$ ST / SQ/ UA	223 / 410/ 148	$^\circ\text{C}/\text{W}$
Package Power Dissipation, ( $P_D$ )	ST / SQ/ UA	400 / 230/ 606	mW

*Note:* Exceeding the absolute maximum ratings may cause permanent damage. Exposure to absolute maximum-rated conditions for extended periods may affect device reliability.

#### Electrical Specifications

DC Operating Parameters :  $T_a=25^\circ\text{C}$ ,  $V_{DD}=3.0\text{V}$

Parameters	Test Conditions	Min	Typ	Max	Units	
Supply Voltage, ( $V_{DD}$ )	Operating	1.65		3.5	V	
Supply Current, ( $I_{DD}$ )	Awake State		1.4	3	mA	
	Sleep State		3.6	7	$\mu\text{A}$	
	Average		5	10	$\mu\text{A}$	
Output Leakage	Output off			1	$\mu\text{A}$	
Output High Voltage, ( $V_{OH}$ )	$I_{OUT}=0.5\text{mA}$ (Source)	$V_{DD}-0.2$			V	
Output Low Voltage, ( $V_{OL}$ )	$I_{OUT}=0.5\text{mA}$ (Sink)			0.2	V	
Awake mode time, ( $T_{aw}$ )	Operating		40	80	$\mu\text{s}$	
Sleep mode time, ( $T_{sl}$ )	Operating		40	80	mS	
Duty Cycle, ( $D, C$ )			0.1		%	
Electro-Static Discharge	HBM	4			KV	
Operate Point,	$(B_{OPS})$	S pole to branded side, $B > BOP$ , $V_{out}$ On		43	50	Gauss
	$(B_{OPN})$	N pole to branded side, $B > BOP$ , $V_{out}$ On		-50	-43	
Release Point	$(B_{RPS})$	S pole to branded side, $B < BRP$ , $V_{out}$ Off		20	33	Gauss
	$(B_{RPN})$	N pole to branded side, $B < BRP$ , $V_{out}$ Off		-33	-20	
Hysteresis, ( $B_{HYS}$ )	$ BOPx - BRPx $		10		Gauss	

**Typical Application circuit**

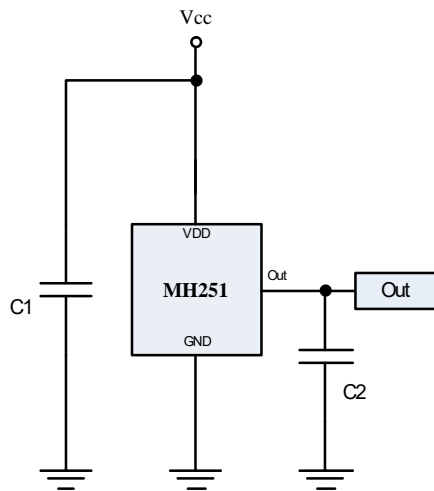

C1 : 10nF

C2 : 100pF

**Sensor Location, package dimension and marking**

**ST Package(TSOT-23)**

**(Top View)**

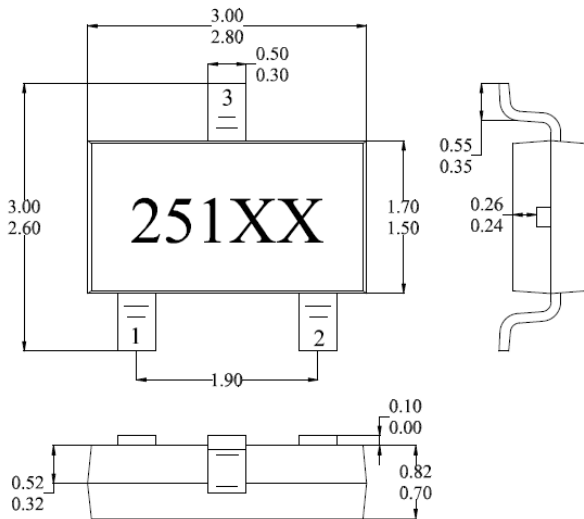

**Hall Plate Chip Location**

**(Bottom view)**

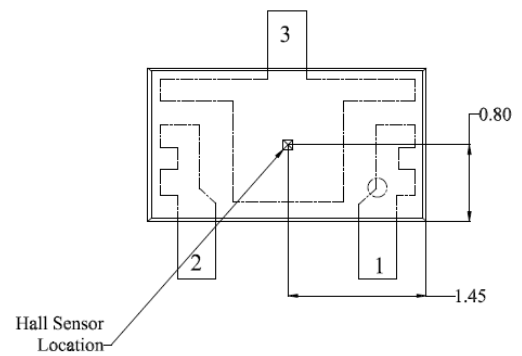

**(For reference only) Land Pattern**

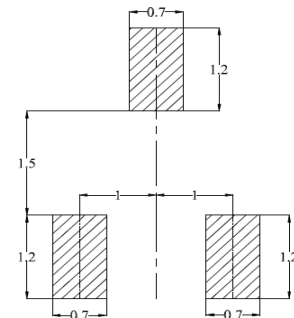

**NOTES:**

1. PINOUT (See Top View at left:)  
 Pin 1 VDD  
 Pin 2 Output  
 Pin 3 GND
2. Controlling dimension: mm;

### SQ Package

(Top View)

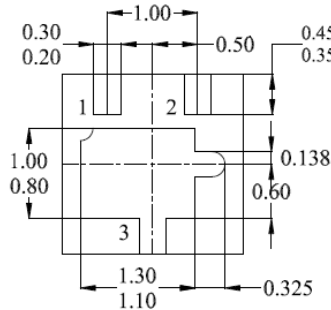
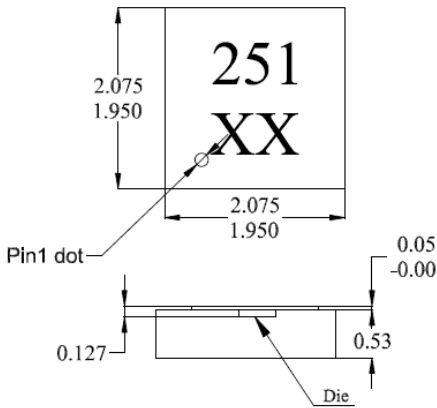

Bottom View

#### NOTES:

- PINOUT (See Top View at left)  
Pin 1 VDD  
Pin 2 Output  
Pin 3 GND
- Controlling dimension: mm;
- Chip rubbing will be 10mil maximum;
- Chip must be in PKG. center.

### Hall Plate Chip Location

(Top view)

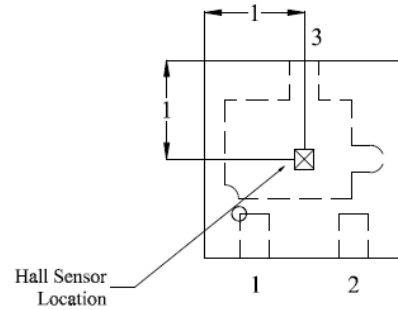

(For reference only) Land Pattern

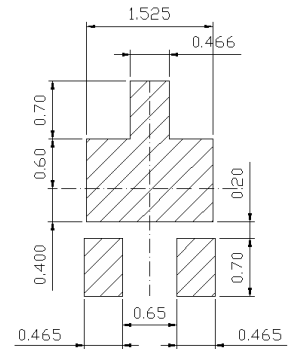

### UA Package

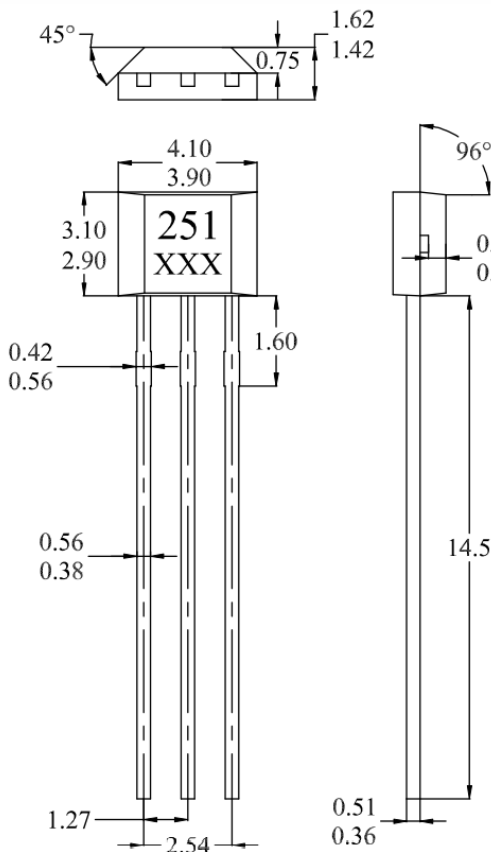

#### NOTES:

- Controlling dimension: mm
- Leads must be free of flash and plating voids
- Do not bend leads within 1 mm of lead to package interface.
- PINOUT:  
Pin 1 VDD  
Pin 2 GND

### Hall Chip Location

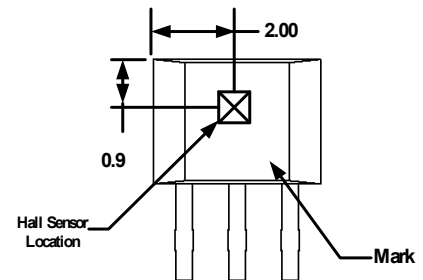

### Output Pin Assignment

(Top view)

